



ROBROY
INDUSTRIES
RACEWAY DIVISION

Manufacturer Recommendations For Hygienic Installations

Application

Robroy Stainless and patented Rocket Rack® Hygienic products have been designed and tested to help meet the demanding requirements of support systems for electrical raceways, cable tray and mechanical process piping in areas where hygienic (sanitary) performance is critical.

Overview

To ensure product performance and safety requirements, installers should reference National Electric Code® (NEC®) guidelines, manufacturer recommended installation instructions and local codes and requirements. It is also important to reference NEC Article 300.6 "Protection Against Corrosion and Deterioration" and Article 344.10 (B) (1) "Corrosive Environments". Materials shall be suitable for the environment in which they are installed and approved for the condition.

General Installation Guidelines

- Proper installation is critical to ensure the best performance, service life and hygienic conditions for the support means of raceway systems, cable tray and/or process piping.
- In order to achieve the best hygienic results and prevent the harboring of microorganisms and other residues, electrical and mechanical installations should be treated as a system.
- Installation should conform with hygienic design principles as outlined in documents such as NSF/ANSI/3-A/SSI 14159-1 and/or EHEDG DOC 8. Recommended adherence includes:
 - Utilizing approved material.
 - Creating surfaces and geometry that is easy to clean, smooth and without crevices or cracks.
 - Eliminating or minimizing exposed threads.
 - Preventing the ingress of water and pests.
 - Limit product or liquid collection.
 - Controlled compression, appropriate groove shape and surface geometry of static seals.

- Compatibility with other plant systems & requirements (transitions).
- System layout and drainability.
- Support structures mounted to walls or floors should be sealed, and allow enough space for the cleaning and sanitizing process.
- Contact points should be minimal.

Industry standard recommends that installers working on the project be certified. Qualified installation provides these benefits:

- End users receive hygienic installation for the best performance, service life and hygienic conditions in the facility.
- Professional installers learn the benefit of providing hygienic materials and installation methods to the end user.
- Contractors achieve more cost-effective installation, providing value to the end user.

Installer certification consists of training that may include classroom and hands-on instruction encompassing:

- Proper installation techniques and tools.
- Hands-on instruction for supports and raceway products.
- Interactive discussion of techniques and troubleshooting.
- Examination at the end of training period.

Only installers who present authorized, unexpired credentials confirming instruction and examination are officially certified. Installer certification is free of charge and available virtually, at the job site, contractor's shop, factory or wherever is convenient.

Installation Details

Rocket Rack Tented™ and Rocket Rack Standard For Sanitary/Hygienic Installs

The Rocket Rack should be installed using only the mounting holes provided.

TRAPEZE MOUNT (ANGLE): Rocket Rack Standard (Profile ↘) with slot and rod-mounting holes cut in the flat leg of the angle OR **Rocket Rack Tented™** (Profile ↗) with slot and rod mounting holes cut into the peak of the angle. Support racks shall be installed with slot and mounting holes pointing in an upward direction.

Conduits, cable tray and process piping shall be secured along the slot, fastened with Rocket Rack U-Bolts and hygienic beveled capnuts or Standoffs and Sanitary Split-Ring Clamps, being mindful of load limitations for each length of support rack. Installer shall leave adequate space between conduits, cable tray or process piping to allow for the cleaning and sanitizing process. Hanger Rods for trapeze-mounted racks shall be **Rocket Rod™**, stainless or Zinc-plated threaded rod with FDA-Certified PVC encasement with no exposed threads or slick stainless rods with minimal threads. Support racks shall be

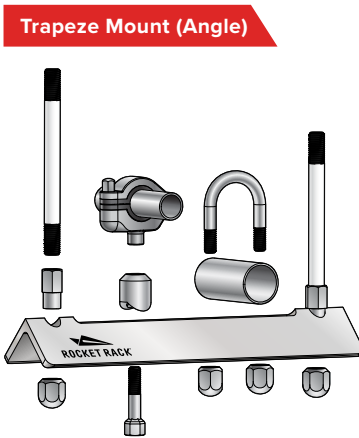

fastened to hanger rods and specialty stainless hardware as supplied with **Rocket Rack Tented™** racks.

Rods shall be attached to building structure per local building codes.

TRAPEZE MOUNT: MULTIPLE TIER (WITH CONDUIT AND PIPING):

Create multiple tiers by adding support racks below the top rack, utilizing stainless rod couplers and same type of mounting rod to underside of 2nd rack, allowing adequate space between racks for the cleaning and sanitizing process.

Conduits, cable tray and process piping shall be secured along the slot, fastened with Rocket Rack U-Bolts and locknuts or Standoffs and Sanitary Split-Ring Clamps, being mindful of load limitations for each length of support rack. Installer shall leave adequate space between conduits, cable tray or process piping to allow for the cleaning and sanitizing process.

Rods shall be attached to building structure per local building codes.



Rocket Rack Flat and Rocket Plate™ For Sanitary/Hygienic Installs

Rocket Rack Flat is for Wall and Rocket Post™ installations only. Never hang Rocket Rack flat trapeze style.

WALL-MOUNT (FLAT): Rocket Rack Flat (Profile: —)

Flat stock shall be mounted off the wall with **Rocket Rod™**, slick stainless rod or stainless Rocket Spacers utilizing appropriate hardware, such as stainless locknuts, leaving a minimum of 2" from the wall to allow for the cleaning and sanitizing process.

Conduits, cable tray and process piping shall be secured along the slot, fastened with Rocket Rack U-Bolts and beveled capnuts or standoffs and sanitary split-ring clamps. Installer shall leave adequate space between conduits, cable tray or process piping to allow for the cleaning and sanitizing process.

Rocket Plate™ with gasket for single conduit or process pipe shall be secured to wall with appropriate hardware. Install Sanitary Split Ring clamp from center mounting hole of Rocket Plate™ using Rocket Rod™ or smooth stainless rod, leaving a minimum of 2" from the wall to allow for the cleaning and sanitizing process.

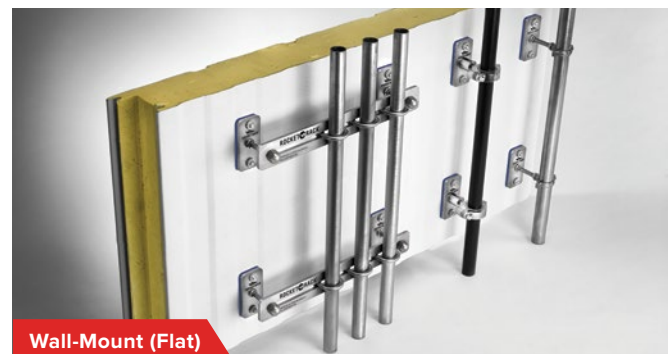
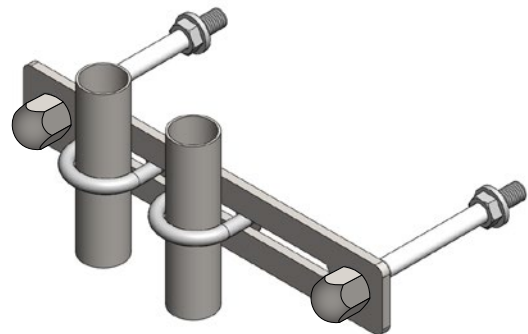

Rocket Posts™ and Post-Tented™ Racks For Sanitary/Hygienic Installs

POST MOUNT: Rocket Posts™ shall be installed with stainless anchor bolts and stainless capnuts or other appropriate anchors so that base is 2" above the floor, applying non-shrink grout between floor and base, creating a sloped surface. Seal grout with epoxy floor coating.



Span posts with:

ROCKET RACK FLAT for Vertical Conduit, Cable Tray and Process Piping Runs and Mounting Equipment

Rocket Rack Flat, secures to 1 post with Rocket Rack U-bolts and beveled capnuts. Mount equipment to flat stock using Rocket Spacers and hardware with locknuts. Conduit, cable tray and process piping shall be secured with Rocket Rack U-bolts and beveled capnuts or standoffs and sanitary split-ring clamps.

POST-TENTED™ RACKS for Horizontal Conduit, Cable Tray and Process Piping Runs

Post-Tented™ secures to Rocket Posts™ with Rocket Rack U-bolts and beveled capnuts with the peak of the angle pointed in the upward direction to prevent the collection of moisture and debris. Conduits, cable tray and process piping shall be secured along the slot, fastened with Rocket Rack U-Bolts and beveled capnuts or standoffs and sanitary split-ring clamps.



Rocket Posts Extension Arms

Extension arms contoured connection point fits the curvature of the Rocket Post and is secured with the custom Rocket U-Bolt and beveled cap nuts included with the extension arm. Conduit, cable tray and process piping shall be secured along the slot, fastened with Rocket Rack U-Bolts and beveled cap nuts, ordered separately.

Stainless Conduit and Conduit Fittings For Sanitary/Hygienic Installs

When installing stainless steel conduit and conduit fittings the installer shall use tools specifically designed for the product. During the threading and bending process, the installer should use die heads and shoes that are limited to stainless steel only. This will prevent the possibility of cross contamination of dissimilar metals.

Clamping: When clamping stainless steel conduit, it is important to limit marks or scarring on the exterior surface of the conduit. This is important because it limits the area where bacteria can collect, form and grow. Conduit should be clamped tightly to prevent spinning of the conduit during the threading process.

Cutting: A roller cutter or saw is recommended for cutting stainless steel conduit. It is important to make sure the cut is straight and square to ensure proper thread engagement. The installer should next ream the interior of the cut end. A reamer is used to remove any rough internal edges caused by cutting to prevent insulation damage during wire pulling.

Threading: Choose the correct dies based on the trade size that is to be threaded. Always use new die heads or die heads limited to stainless steel conduit to prevent cross contamination of dissimilar metals. Die heads should be sharp; inspect dies and replace when worn. Conduit threads are NPT tapered threads, use standard ¾-inch per foot taper National Pipe Thread die. To gauge the correct thread length, place the provided thread protector over the area to be threaded. Make a mark around the conduit and do not thread past the length of the die. NEC requires a minimum of five threads of engagement for NPT threads. Note: It is a good practice to thread one thread short to prevent butting of conduit in a coupling. Never over-thread conduit because exposed threads are not recommended in hygienic installations because they serve as collection points for waste and bacteria. Use a high quality, food grade (NSF rated) thread cutting oil to ensure proper threading, protection of die heads and to avoid chemical contamination. Once conduit is threaded, remove the die head and inspect conduit threads.

Threads should be sharp, clean and free of any defects such as chips or burrs. After threading, clean the threads and conduit interior with a food grade degreasing spray to prepare for the application of the approved thread compound. Cleaning ensures proper adherence of compound to the metal substrate.

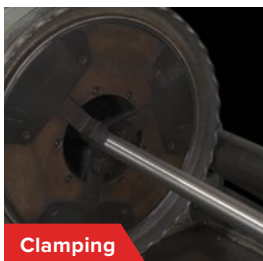

Clamping

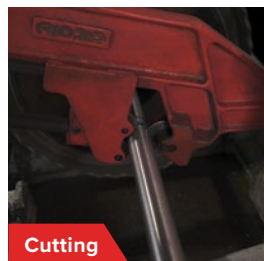

Cutting

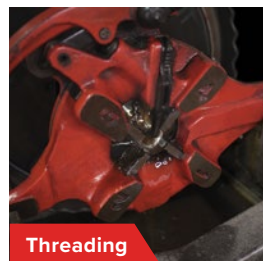

Threading

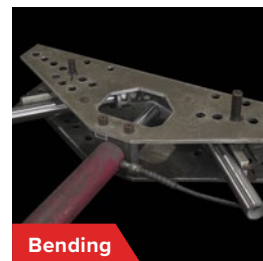

Bending

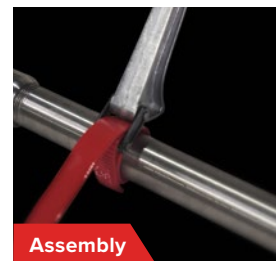

Assembly

*Important: Robroy Stainless UL 6A Couplings are based on the industry standards for traditional couplings. When in a hygienic environment an IP69K coupling/fitting with tapered threads and gasket must be used to maintain the IP69K environmental rating.

Bending: Reference operation manual of bender for detailed information on conduit bending including machine capabilities. When bending stainless conduit, use shoes that are limited to stainless to prevent cross contamination of metals. Also use rubbing alcohol to clean the inside of the shoe and the area of conduit you wish to bend. Never use lubricant in the shoe or on the conduit. Lubricant allows the conduit to slip above the centerline of the shoe, resulting in flattening of the elbow. Use caution when bending stainless steel conduit, the power required to bend stainless is greater than carbon steel.

- Hand Bending is suitable for conduit sizes 1/2" – 3/4".
- Proper equipment in good condition must be used to prevent ovalization of threaded ends to ensure proper gasket seal.
- Stainless steel factory elbows are available as an alternative to field bending.

Assembly:

- When assembling stainless steel conduit, installer shall use tools that will prevent scratching or marring of the surface.
- In order for the installed system to have the desired effect, only products that have the NSF rating shall be used.
- Stainless Steel products marked with the Hygienic Logo are easily identified as a hygienically designed component.
- Installer shall verify that support products comply with manufacturer-published and Professional Engineer certified load ratings. **It is recommended load ratings be reduced by a Factor of Safety of 2.**
- Conduit body covers should be secured to conduit body only with factory-supplied screws to ensure proper torque.
- When assembling threaded parts it is common industry practice to use a thread lubricant. The use of a thread lubricant can aid in assembly. Please note that the final determination of acceptance of a thread lubricant must be made by the local Authority Having Jurisdiction (AHJ). Testing of products for UL certification is done without thread lubricants. When using thread lubricants, ensure they are food-grade rated. It is also important not to use lubricants that contain hydrocarbon solvents on the silicone gasket. Lubricants without the hydrocarbon solvents and are inert would be acceptable because they do not contain any like materials to the silicone gasket.

Transitioning Raceways:

- The components within an hygienic installation are made to work together as a connected system. Always use products with similar environment and sanitary ratings to maintain system performance.
- Always ensure the LFMC is installed with sufficient slack to avoid excessive tension on the conductors at point of connection or termination inside the LFMC.



- When transitioning raceway systems (e.g. from liquid tight flexible metal conduit (LFMC) to rigid conduit or cabling to rigid conduit) ensure the connection is made using a transition fitting designed and approved for the application. Failure to do so may jeopardize the environmental rating of the system, lead to exposed threads and increase risk of potentially shortening the life of the system.

Layout & Drainability:

- Proper layout provides for self-draining or drainability. For draining, appropriate and approved drain shall be used in conjunction with enclosures and at low point location of raceway runs.
- Drains are to reduce the amount of moisture collection in a conduit system due to condensation or inadvertent exposure to environmental conditions not aligned with environmental ratings of the raceway system.
- Drains should always be placed at the lowest point in a conduit run as to not allow parts of the conduit system to fill up with liquids.
- Drain placement should be low enough to floor and distant from production area so as to not risk contamination of product.
- Drains should be checked periodically for proper function and clogging.
- Cleaning can be achieved with the help of compressed air or water. If possible, the product should be removed and the compressed air or water should be applied from inside to outside.

Maintenance

Visual and mechanical inspections of all components should be performed on a regular basis; best practice recommends annual inspection. However, this should be determined by the environment and frequency of use. Maintenance personnel should mechanically check to ensure all parts are properly assembled, secure and tight.

Cleaning

Robroy support and raceway products should be cleaned in accordance with facility cleaning and sanitizing schedules and protocols. Approved cleaning methods include power clean (wet or dry) and/or wipe down.



Robroy Stainless and Rocket Rack products marked with the Hygienic logo indicate that the installed product has been reviewed and listed to both electrical and hygienic standards, as applicable. Products marked with the Hygienic logo add a visual indication of the use of a product designed and tested for use in hygienic/sanitary installations. In addition to the Hygienic logo, those products will also be marked with the electrical certification and Hygienic certification logos. Further details regarding certifications can be found on the respective certification agency websites.

Robroy Stainless and Rocket Rack products are covered by issued patents and additional patents are pending. Robroy Industries values and protects its intellectual property. For more information please visit:

www.robroystainless.com/patents
www.rocket-rack.com/patents